

1

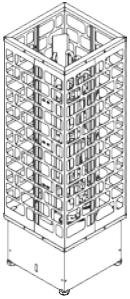

It is advisable to install the Protective Cover with the casing only.

2

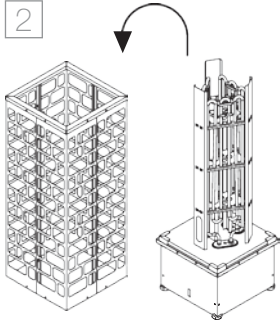

3

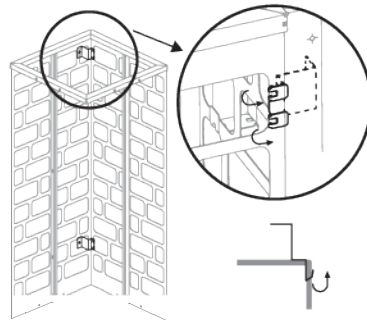

Attach the clips to the corner top hole and below to place the Protective Cover.

4

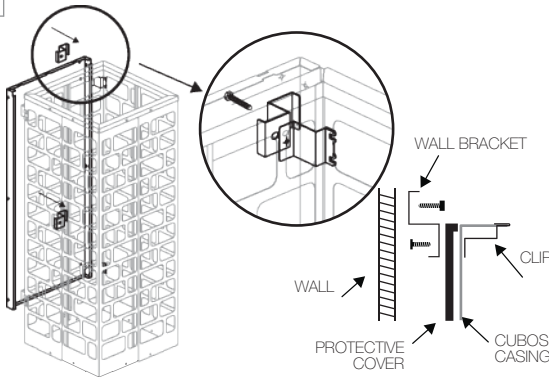

Attach the protective cover 1 together with the wall brackets to the clips.

5

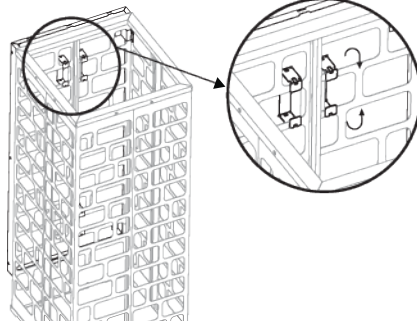

Bend the legs of the protective cover 1 clips to secure.

6

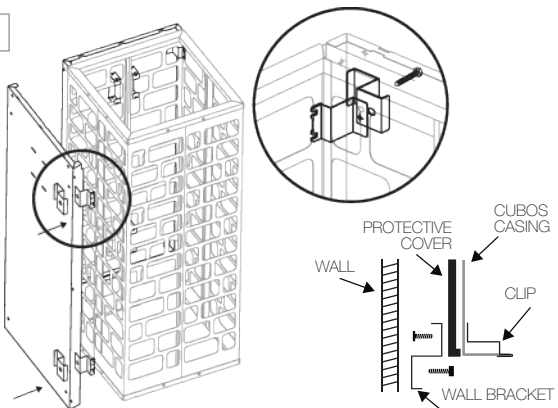

Attach the protective cover 2 together with the wall brackets to the clips in reverse position as protective cover 1.

7

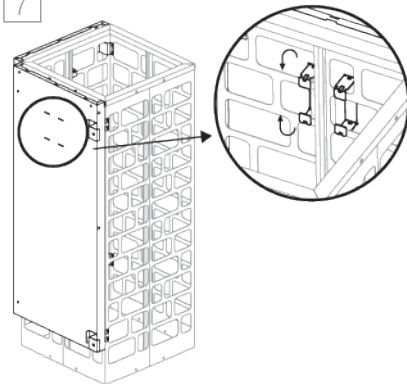

Bend the legs of the protective cover 2 clips to secure.

8

Fold the reflector before mounting.

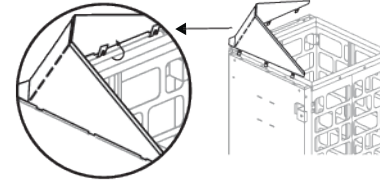

Insert the reflector and bend the legs to the assigned holes on the protective covers to fasten.

10

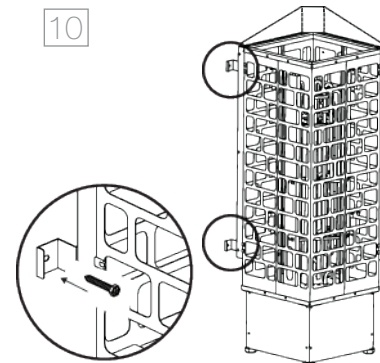

Secure the bracket with screws to the wall.

9

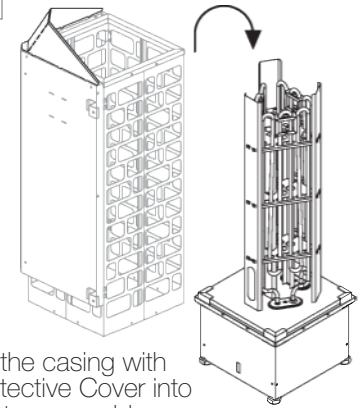

Return the casing with the Protective Cover into the heater assembly.

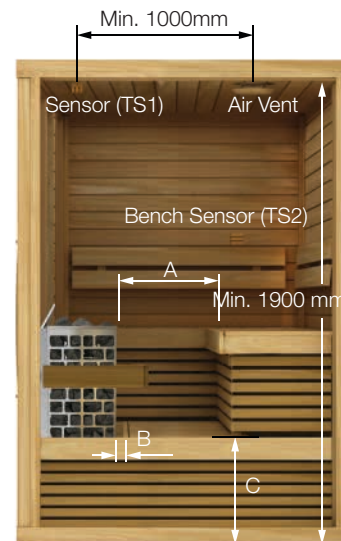

Safety Distance (mm)

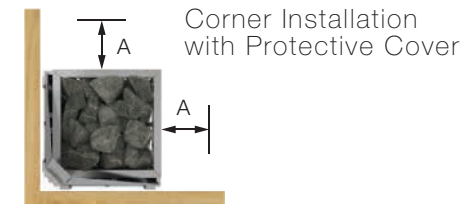

HEATER MODEL	A (MIN.)	B (MIN.)	C (MAX.)
CUB3-45 Ni2 NS NB	100	45	700
CUB3-60 Ni2 NS NB	100	45	700
CUB3-75 Ni2 NS NB	100	45	700
CUB3-90 Ni2 NS NB	125	45	700